



<b>Subject:</b>  CAMSHAFT INSTALLATION INFORMATION	<b>Bulletin No:</b> 01-016/02
	<b>Last Issued:</b> 5/7/2002

## APPLICABLE MODEL(S)/VINS

All 1995-2002 Millenia S (KJ engine)

## DESCRIPTION

When reinstalling camshafts during engine repairs, the original timing paint marks may have been worn away over time. If this is the case, index mark and install the intake and exhaust camshafts using the procedure outlined in this bulletin.

**NOTE:** The procedure for the right and left cylinder banks are different. Be sure to follow each procedure closely. Failure to install the camshafts correctly may lead to poor running engine or engine damage.

**CONSUMER NOTICE:** The information and instructions in this bulletin are intended for use by skilled technicians. Mazda technicians utilize the proper tools/equipment and take training to correctly and safely maintain Mazda vehicles. These instructions should not be performed by "do-it-yourselfers." Customers should not assume this bulletin applies to their vehicle or that their vehicle will develop the described concern. To determine if the information applies, customers should contact their nearest authorized Mazda dealership.

### RIGHT CYLINDER BANK PROCEDURE

**NOTE:** This is the cylinder bank that is closest to the bulkhead.

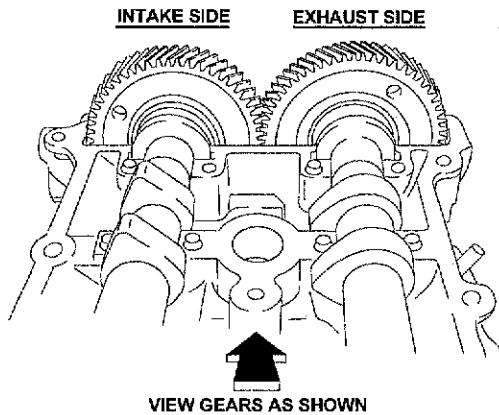
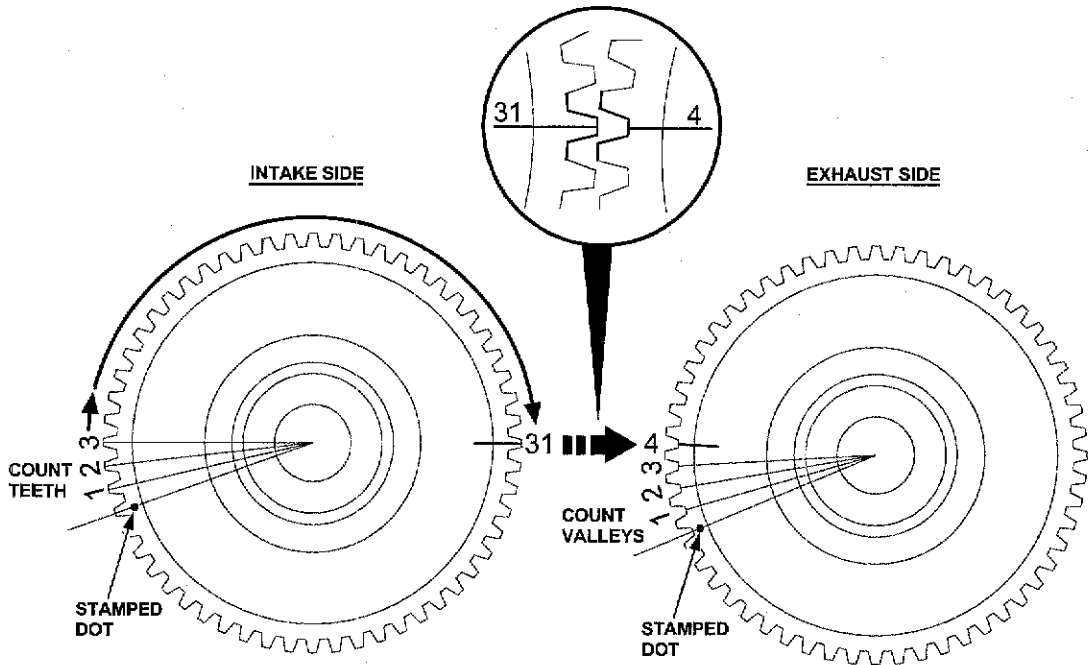

02\_1076a

#### INTAKE CAMSHAFT INDEXING (Right Cylinder Bank)

1. From the back side of the intake camshaft gear, locate the small stamped dot. (Clean the camshaft gear as

needed to locate the dot.)

2. Starting from the tooth stamped with the dot, count clock-wise thirty-one (31) teeth.
3. Mark the 31st tooth with a scribe line.

**EXHAUST CAMSHAFT INDEXING (Right Cylinder Bank)**

1. From the back side of the exhaust camshaft gear, locate the small stamped dot. (Clean the camshaft gear as needed to locate the dot.)
2. Starting from the valley stamped with the dot, count clock-wise four (4) valleys.
3. Mark the 4th valley with a scribe line.

**INSTALLING CAMSHAFTS (Right Cylinder Bank)**

1. Align the marked intake gear tooth with the marked exhaust gear valley.
2. Install the camshafts onto the cylinder head.
3. Verify the alignment of the scribed marks.

**LEFT CYLINDER BANK PROCEDURE**

**NOTE:** This is the cylinder bank that is closest to the radiator.

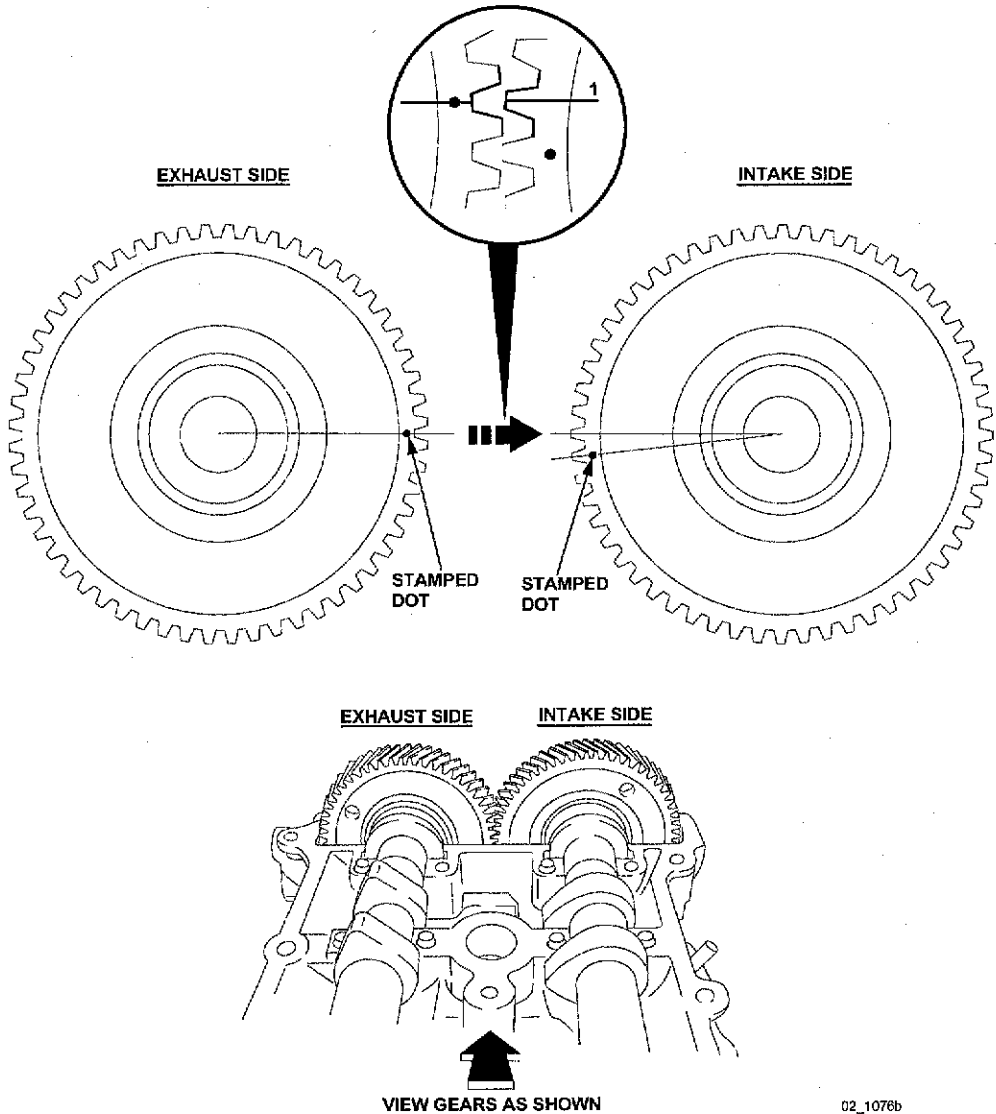

02\_1076b

**INTAKE CAMSHAFT INDEXING (Left Cylinder Bank)**

1. From the back side of the intake camshaft gear, locate the small stamped dot. (Clean the camshaft gear as needed to locate the dot.)
2. Starting from the tooth stamped with the dot, count clock-wise one (1) tooth.
3. Mark the 1st tooth with a scribe line.

**EXHAUST CAMSHAFT INDEXING (Left Cylinder Bank)**

1. From the back side of the exhaust camshaft gear, locate the small stamped dot. (Clean the camshaft gear as

needed to locate the dot.)

2. Mark the dotted valley with a scribe line.

**INSTALLING CAMSHAFTS (Left Cylinder Bank)**

1. Align the marked intake gear tooth with the marked exhaust gear valley.
2. Install the camshafts onto the cylinder head.
3. Verify the alignment of the scribed marks.